

UniBloc Analytical Balances

ATX/ATY Series



ติดต่อบริษัท เนโอนิกส์ จำกัด

Tel: 02-077-7602 หรือ 061-8268939

E-mail: sale@neonics.co.th เว็บไซต์ www.neonics.biz



Durable, high-performance aluminum alloy mass sensor UniBloc

The ATX/ATY series incorporates a one-piece aluminum alloy mass sensor technology (UniBloc), first introduced by Shimadzu for precision balances in 1989. It excels in performance, and resists deterioration and damage by ordinary impacts. The UniBloc's compact, uniform structure replaces 70 parts found in a conventional electromagnetic balance sensor assembly and ensures stable temperature characteristics, excellent response time and stable corner-load performance. The UniBloc design permits a consistency of production that assures reliability and a long operational life.



Touch-key Calibration

Automated calibration can be started by pressing keys. (ATX series)
Also, your external calibration weights can be used for span calibration. (All models)



3 Benefits of UniBloc.



ติดต่อบริษัท เนโอนิกส์ จำกัด

Tel: 02-077-7602 หรือ 061-8268939

E-mail: sale@neonics.co.th เว็บไซต์ www.neonics.biz



Easy Setting Best fit to weighing application

Quickly adjust the desired ratio of stability and response for every application, even during measurement, with one-touch operation.



Calibration record

You can leave a record of execution of calibration. With serial number and ID of balance.

Large pan size

This model has the largest weighing pan in the class (91mm diameter).

Multiple weighing units

In addition to grams (g), weigh in ct, mg, oz, etc. or a custom conversion units.



Expanded Piece Counting Function

Unit weights of up to 5 different samples can be easily entered, stored and recalled for use.



Comparator Function

Compare samples to target values or pass/fail criteria and clearly indicate the results.



Formulation Mode

Convenient for making many measurements of minute samples and seeking the total mass.

% measurement

The weight of the sample is converted to a percentage of the reference weight.

Power saving function

When weighing operation ends. Power automatically turns off after a fixed or pre-set time.



WindowsDirect Communication Function

Send balance data to Excel or other Windows applications without any data communication software installation required. By combining standard AutoPrint functions with typical spreadsheet functions, even difficult applications can be easily automated.

*RS232C interface is needed.

Password lock

In order to ensure that the menu settings are not changed by mistake, the person managing the Balance controls the password and can prohibit menu operation.



ติดต่อบริษัท นีโอนิคส์ จำกัด

Tel: 02-077-7602 หรือ 061-8268939

E-mail: sale@neonics.co.th เว็บไซต์ www.neonics.biz

ATX/ATY Series
UniBloc Analytical Balances

Dimensions

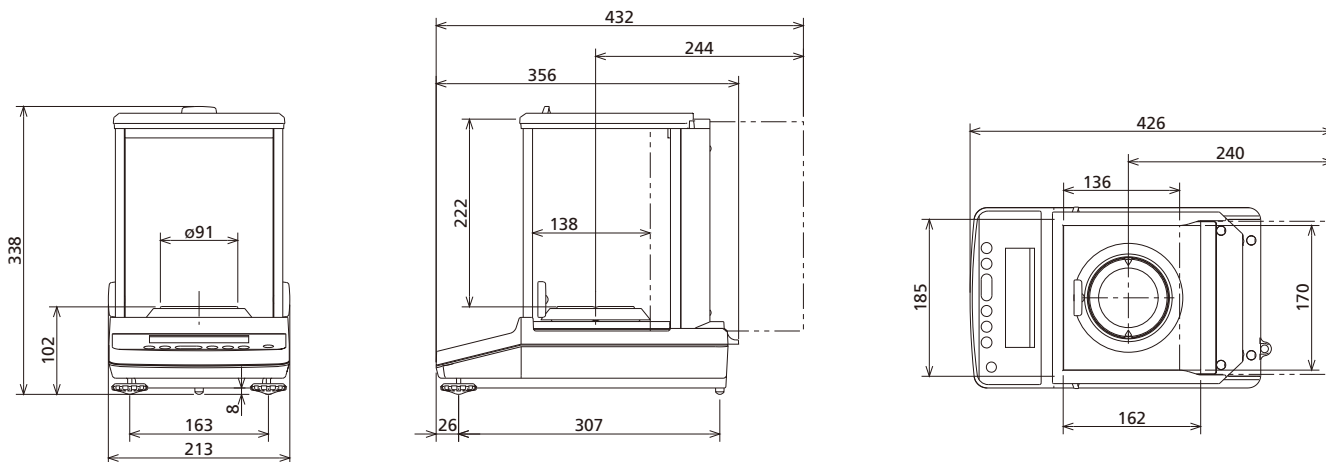

Specifications

ATX/ATY series

Model	ATX84	ATX124	ATX224	ATY64	ATY124	ATY224
Capacity	82g	120g	220g	62g	120g	220g
Minimum Display	0.1mg					
Repeatability (Standard Deviation)	≤0.1mg					
Linearity	± 0.2mg					
Stabilisation Time*1	Approx. 3.0 seconds					
Operating Temperature and Humidity Limits	5-40°C 20-85%*2					
Temperature Coefficient for Sensitivity (10-30°C)	± 2 ppm/°C					
Pan Size (mm) approx.	ø91					
Main Body Dimensions (mm) approx.	213(W)×356(D)×338(H)					
Main Body Weight (kg) approx.	6.2			6.0		
Power Requirement	12V, 1A					
Internal Calibration	●			—		

*1 The Stabilisation time is a representative value
 *2 No condensation

Options

Description
EP-80 Printer
EP-90 Printer
I/O-RS cable
Protection Cover
STABLO-EX static remover
USB conversion kit



Shimadzu Corporation

ติดต่อบริษัท เนโอนิกส์ จำกัด

Tel: 02-077-7602 หรือ 061-8268939

E-mail: sale@neonics.co.th เว็บไซต์ www.neonics.biz

Company names, product/service names and logos used in this publication are trademarks and trade names of Shimadzu Corporation or its affiliates, whether or not they are used with trademark symbol "TM" or "®". Third-party trademarks and trade names may be used in this publication to refer to either the entities or their products/services. Shimadzu disclaims any proprietary interest in trademarks and trade names other than its own.

For Research Use Only. Not for use in diagnostic procedures. The contents of this publication are provided to you "as is" without warranty of any kind, and are subject to change without notice. Shimadzu does not assume any responsibility or liability for any damage, whether direct or indirect, relating to the use of this publication.